

Infinitas Continuous System

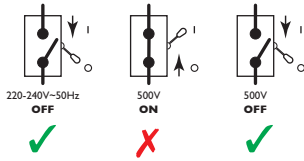

IMPORTANT

Disconnect before High Voltage Insulation testing

IMPORTANT INFORMATION

- This Document and the Tool Kit must be left on site with the end user
- Disconnect electricity supply before installation / To be installed by qualified personnel only
- **Due to the weight of these luminaires, ensure suitable fixings are used when installing!**
- The Infinitas Wiring Harness is rated at 16A, therefore several mains/dimming supplies may be required for larger systems. Mains/dimming supply cable not supplied.
- Before installing please familiarise yourself with the orientation of the Modules Male/Female wiring connections to ensure correct continuity is achieved
- Infinitas Corners can be either left or right handed. Fit the Plug/Harnesses to each Connector Block to maintain a Male/Female connection to the adjoining Module. Ensure the cables are inserted into the correct terminals by matching the cable colours to the Connector Block label to ensure correct polarity.
- When installing, Hacer recommends wearing disposable gloves to avoid fingerprinting to the paint work of the luminaire



Installation
(2 People)

Link Modules



Solo Modules



Wiring Information

Black	L2
Brown	L1
Green/Yellow	Earth
Blue	N
Orange	L3
Red	
White	

Non Dim/Emergency	DALI Dim/Emergency	Switch Dim/Emergency	PIR/PIR DALI/Emergency
Unswitched Live (Emergency)	Unswitched Live (Emergency)	Unswitched Live (Emergency)	Unswitched Live (Emergency)
Switched Live	Unswitched Live	Unswitched Live	Unswitched Live for DALI PIR (Dimmable)
Earth	Earth	Earth	Earth
Neutral	Neutral	Neutral	Neutral
Not used	Not used	Switched Live (DIM)	Unswitched Live for PIR (Switching only)
Not used	DALI 1	Not used	Not used
Not used	DALI 2	Not used	Not used

Maintenance

- Disconnect electricity supply before carrying out maintenance, including cleaning Diffusers.
- Maintenance must be carried out by two persons.
- When removing Modules and Geartrays ensure that they are lowered parallel to the mounting surface.
- When replacing Suspended Modules the Suspension Wires must also be replaced.

Removing Geartrays (2 persons)

- Remove the Diffuser/Fascia.
- Remove the Geartray fixing screws ensuring that both ends of the Geartray are supported during the procedure.
- The Geartray will then drop free of the Module allowing the electrical connections to be disconnected.

All Modules - Infinitas Continuous System

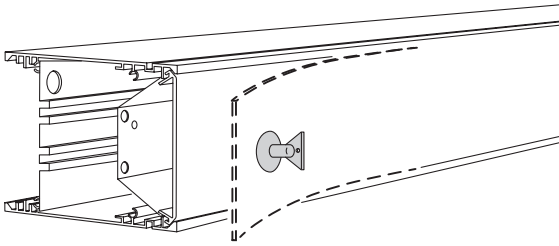

To remove Infinitas Manta Fascias, undo the 3x screws securing the Fascia and then disconnect the plug/socket arrangements.

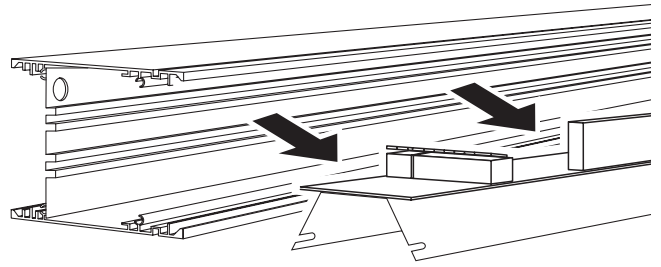

To remove Gear Trays, remove the screws from closed slots, loosen the screws from the open slots but do not remove the screws and slide the Gear Tray out. Temporarily mark matching Diffusers, Gear Trays and Housings.

Mains/dimming supply cable not supplied.

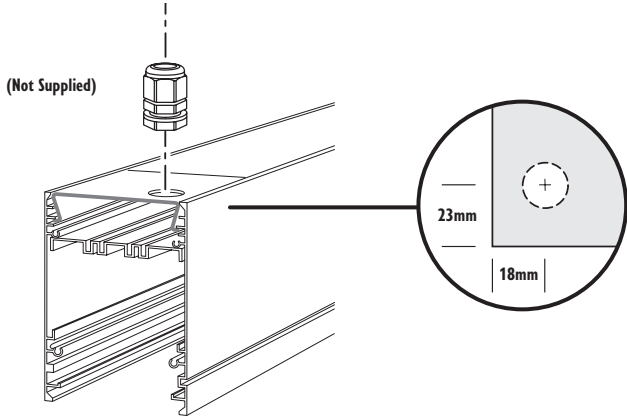

1

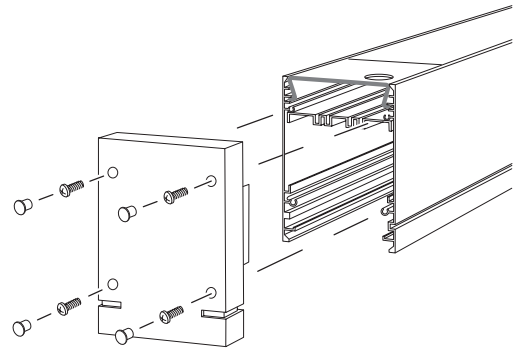

Where applicable
Plug's supplied with Surface and Suspended versions only.

2

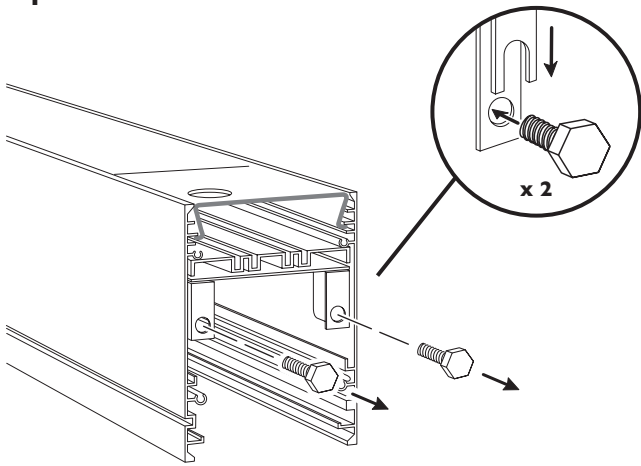

3

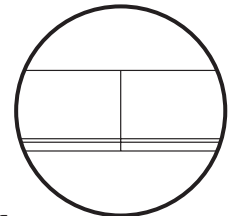
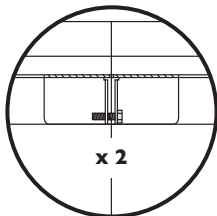
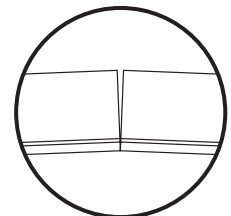
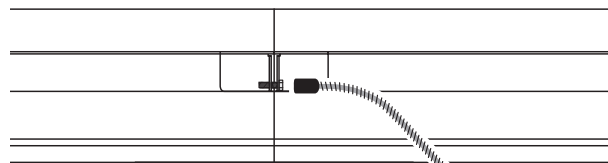
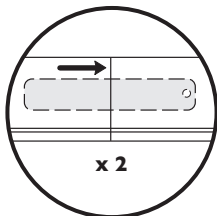

For Bezel Free Systems, plastering up to the 3mm lip should be carried out at this point. Plasterboard Joint Tape should be applied over the bezel and adjoining surface before plastering.

4

Infinitas Corners can be either left or right handed. Fit the Plug/Harnesses to each Connector Block to maintain a Male/Female connection to the adjoining Module. Ensure the cables are inserted into the correct terminals by matching the cable colours to the Connector Block label to ensure correct polarity.

For Direct Indirect Corner Modules, the Suspension Clutch Plates and the Green Plugs may need to be swapped around to ensure mechanical continuity.

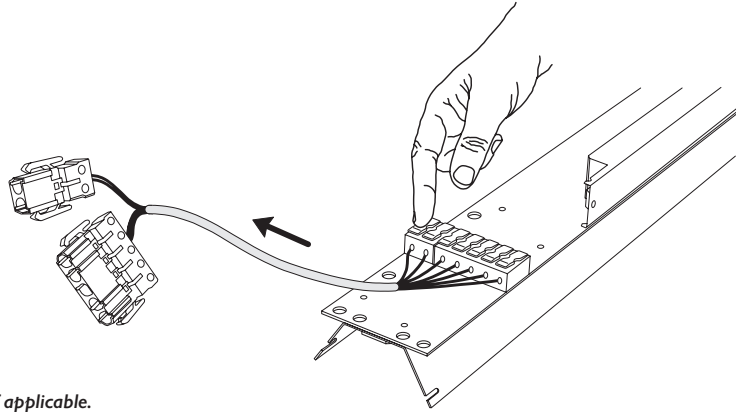

For Modules where mains/dimming supply is to be fed, remove Male plugs, if applicable. Mains/dimming supply cable not supplied.

5

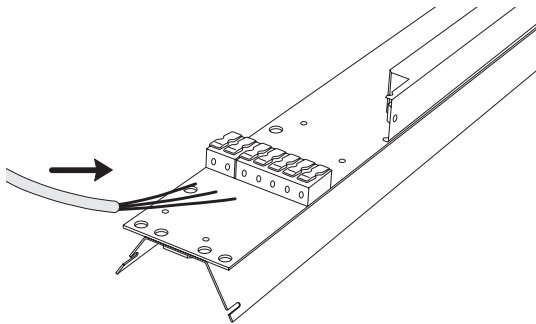

For Direct Indirect Modules make connection. Ensure correct polarity is observed.

For Emergency versions, battery connections should only be made when a permanent mains supply is in place.

For Suspended/Surface versions the Emergency Indicator should be fitted into the pre-drilled hole in the Module. For recessed versions the Emergency Indicator should be fitted into the Indicator Holder which should be fitted into the ceiling adjacent to the Module.

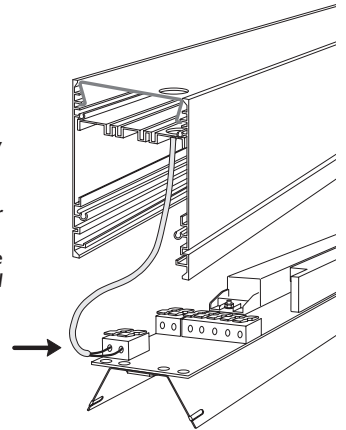

See Wiring Information.

6

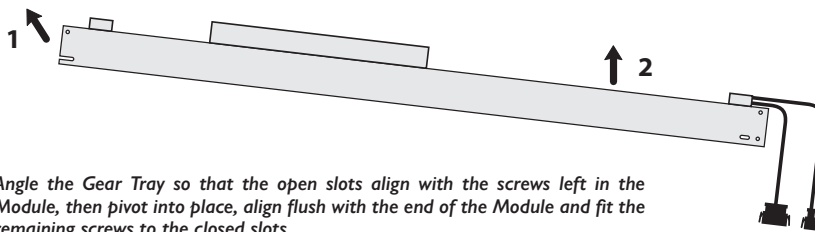
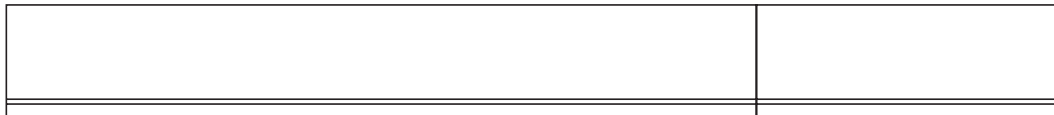

Angle the Gear Tray so that the open slots align with the screws left in the Module, then pivot into place, align flush with the end of the Module and fit the remaining screws to the closed slots.

7

Ensure end of reflectors are aligned with end of Modules. Do not tighten screws until you are certain that the Geartrays are correctly aligned.

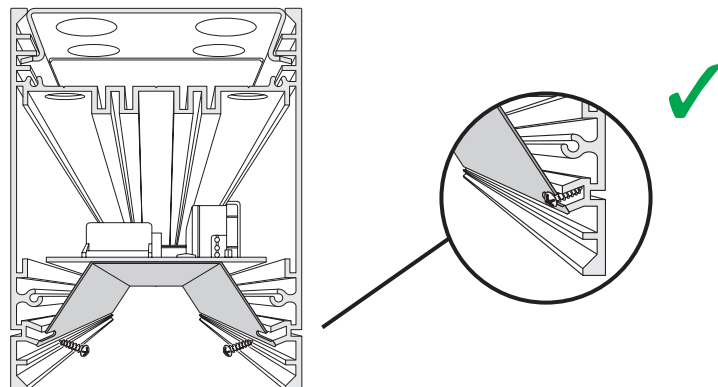

8

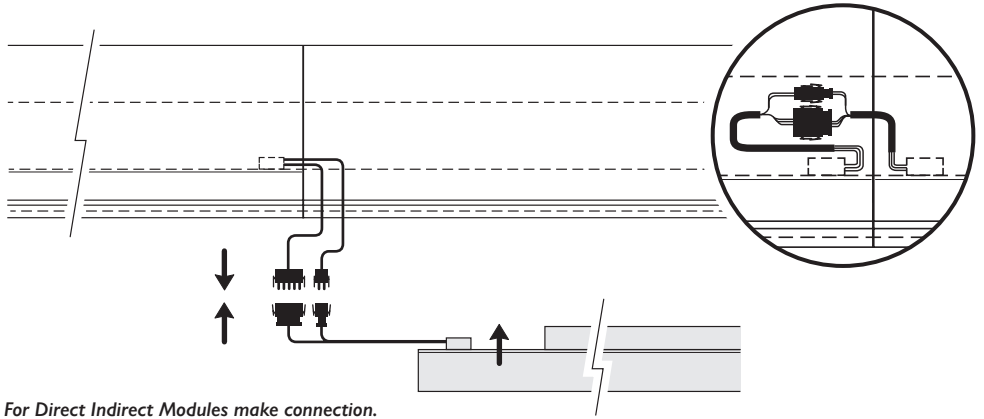
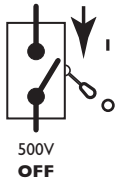

For Direct Indirect Modules make connection.
Ensure correct polarity is observed.

9

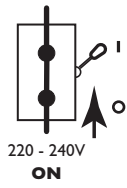

10

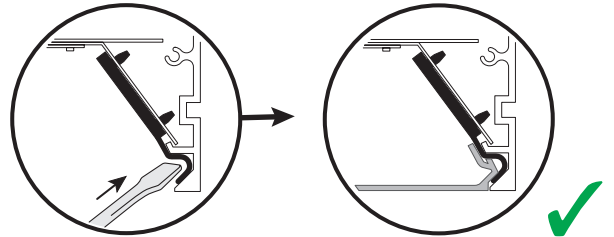
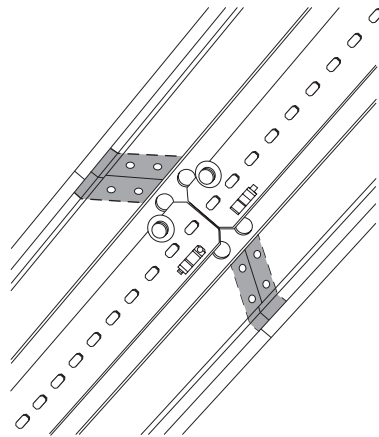
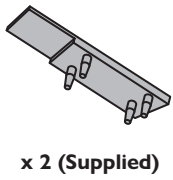

11

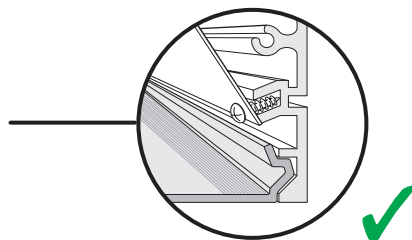
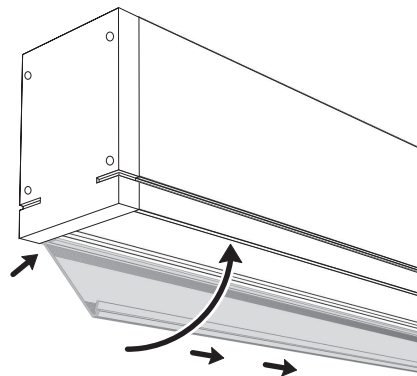

Place hard up against End Cap

Suspended Modules - Infinitas Continuous System

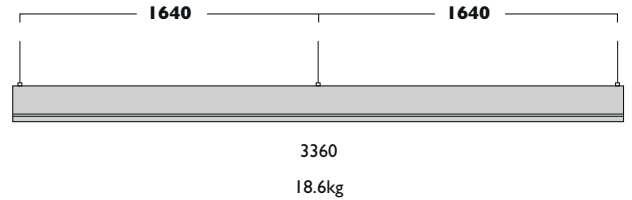
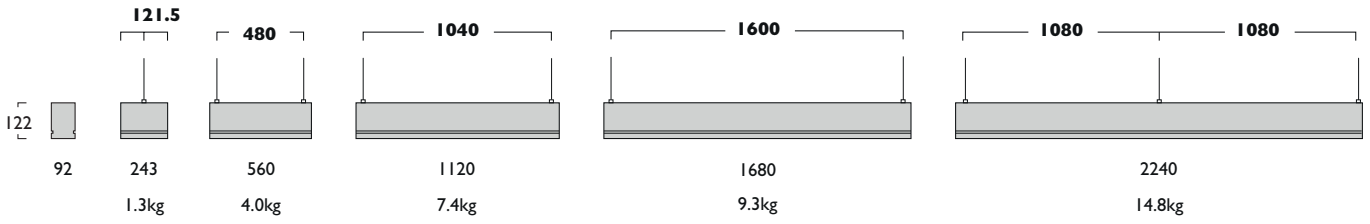

Suspended Modules Fixing Centres (mm)

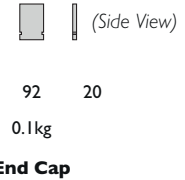
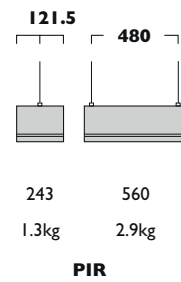
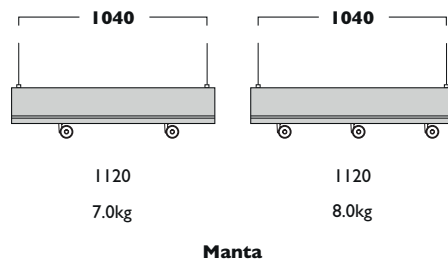
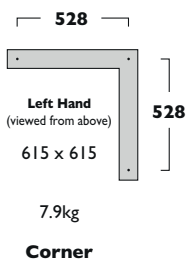

1 _____

IMPORTANT

Due to the weight of these luminaires, ensure suitable fixings are used when installing!

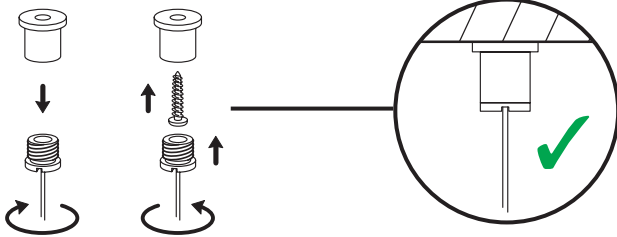

(Screws Not Supplied)

Re-tighten, finger tight only after levelling

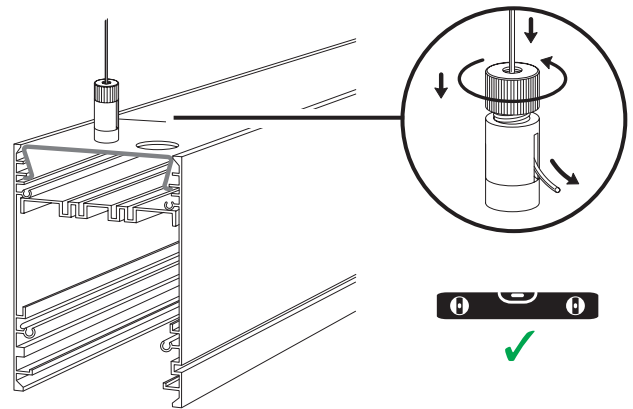

2 _____

Manta Modules (Only)

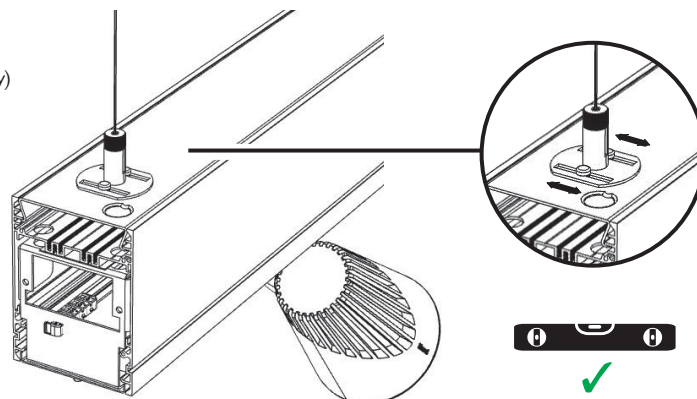

Recessed Modules - Infinitas Continuous System

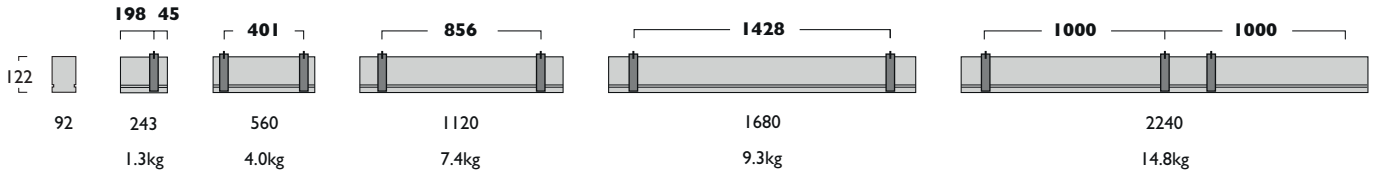

Recessed Modules Fixing Centres (mm)

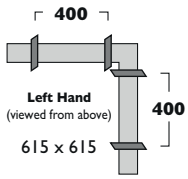
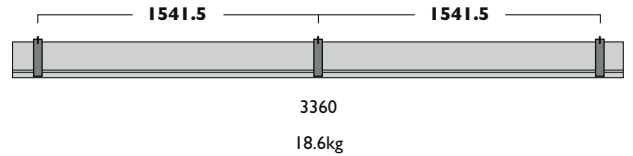

7.9kg
Corner

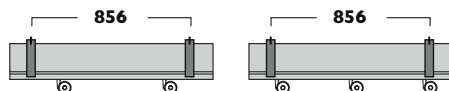

7.0kg 8.0kg
Manta

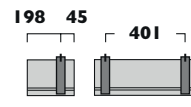

1.3kg 4.0kg
PIR



0.1kg
End Cap

1 _____

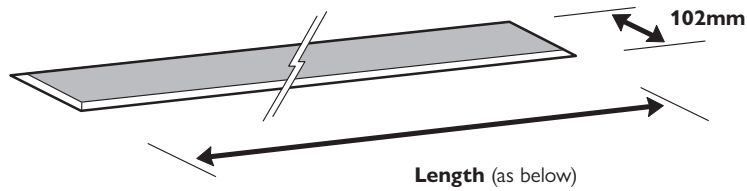

Maximum clamping thickness 35mm

Cut out size: Width 102mm x Total Length of all Modules + 40mm (for End Caps if applicable) + 10mm (clearance)

For Emergency Modules the Indicator must be fitted into the Remote Holder, which requires a 20mm diameter cut out adjacent to the Emergency Module.

2 _____

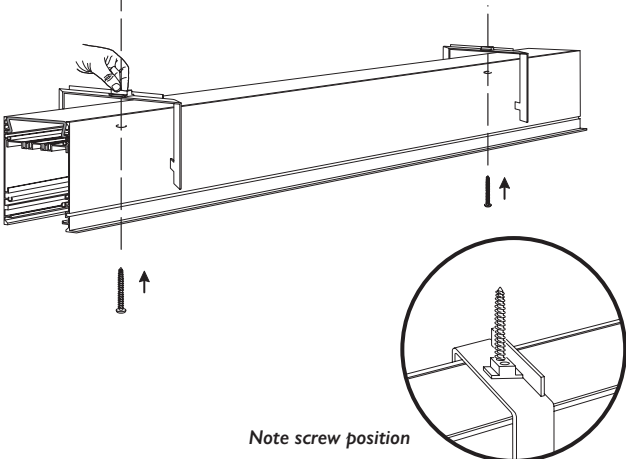

3 _____

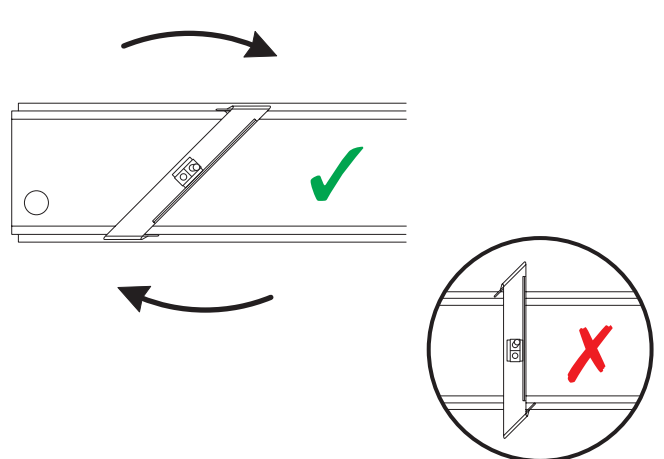

4 _____

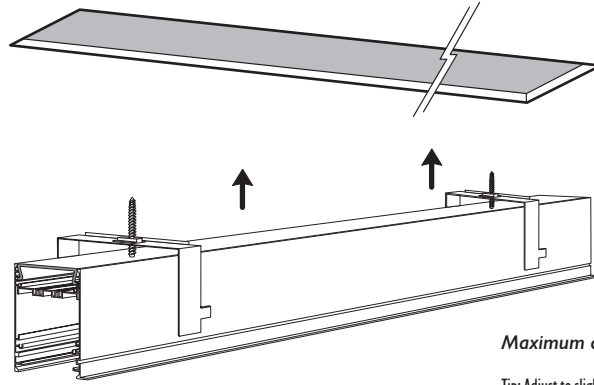

Maximum clamping thickness 35mm

Tip: Adjust to slightly higher than the thickness of the mounting surface

5 _____

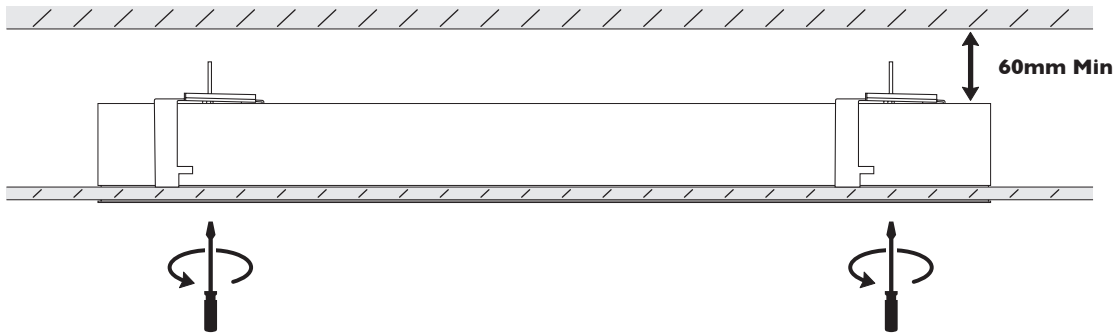

60mm Min

Do not overtighten Clamp Screws

Surface Modules - Infinitas Continuous System

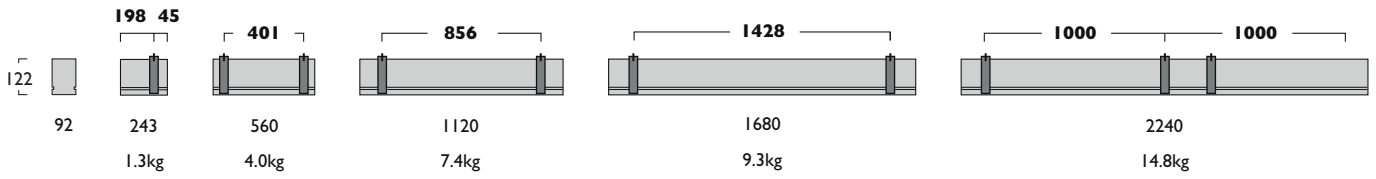

Surface Modules Fixing Centres (mm)

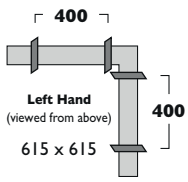
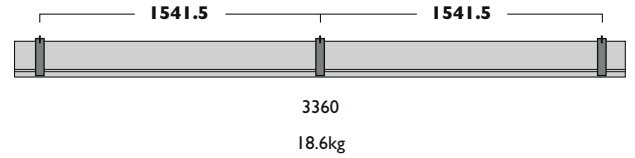

7.9kg

Corner

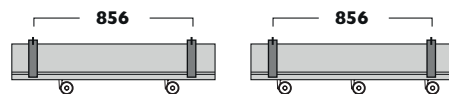

1120

7.0kg

Manta

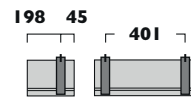

243

1.3kg

560

4.0kg

PIR

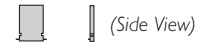

92

0.1kg

End Cap

1

IMPORTANT

Due to the weight of these luminaires, ensure suitable fixings are used when installing!

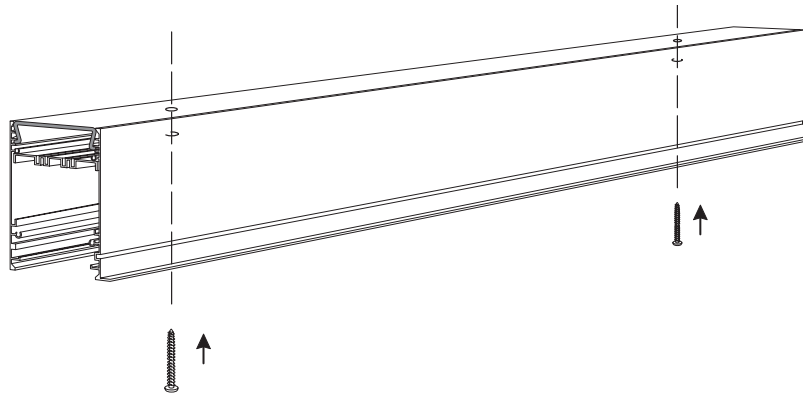

2

